



# “BOP 2 WIN”

## THE GAME OPERATION and INSTRUCTION MANUAL



STING INTERNATIONAL, P.O. BOX 455, ELK GROVE VILLAGE, IL 60007 USA E-mail: [sting2 @ rcn.com](mailto:sting2@rcn.com).

FOR ALL PARTS, SERVICE, AND TECHNICAL SUPPORT

PHONE: 708-598-3720 FAX: 708-598-3720

[WWW.FAMILYFUNCOMPANIES.COM](http://WWW.FAMILYFUNCOMPANIES.COM)

STING INTERNATIONAL, © 2013 ALL RIGHTS RESERVED

# TABLE OF CONTENTS

<b>1. Brief Introduction .....</b>	<b>1</b>
<b>2. Caution .....</b>	<b>1</b>
<b>2-1. Notice for Installation .....</b>	<b>1</b>
<b>2-2. Notice for Operation .....</b>	<b>1</b>
<b>3. Accessories .....</b>	<b>2</b>
<b>4. How to Play .....</b>	<b>2</b>
<b>5. Technical Parameter.....</b>	<b>2</b>
<b>6. Appearance .....</b>	<b>3</b>
<b>7. All Parts Description and Location .....</b>	<b>4</b>
<b>8. Component .....</b>	<b>6</b>
<b>8-1. Meter Board .....</b>	<b>6</b>
<b>8-2. Power Supply Input Panel .....</b>	<b>7</b>
<b>8-3. Coin Mechanism .....</b>	<b>8</b>
<b>8-4. Ticket Dispenser .....</b>	<b>9</b>
<b>9. PIN Connection on Main Board.....</b>	<b>10</b>
<b>9-1. Error Codes .....</b>	<b>10</b>
<b>10. Function and score setting instruction .....</b>	<b>13</b>

## 1. Brief Introduction

The novelty coin operated game; “Bop 2 Win” is intended for one Player. The Player try will attempt to use mechanical boxing glove "PUNCH" mechanism in order to “hit” the nose of the Clown character when the moving, lighted ticket score segment reaches the desired score. When the Player presses the “PUNCH” plunger down, the boxing glove mechanism will extend to the Clown’s nose- immediately stopping the moving score segment light once the mechanism has fully extended. The ticket score shown on the Target Score Panel when the light stops will be the ticket amount awarded to the Player at the end of the game.

## 2. Caution

### 2-1. Notice for Installation

- This machine is *only* intended for indoor use.
- After installation, we recommend always lowering the four stabilizing levelers
- Remove power before servicing
- Operate on a level surface
- Avoid operation in high temperatures

### 2-2. Notice for Operation

- Inspect whether the power plug and power cord are in good condition before switching the power on. Make sure that the voltage is suitable for the machine.
- The power supply voltage must be consistent with the specifications on the back of the machine.
- Switch the power off before any maintenance or repair.
- Only qualified persons can examine and repair the electric control units.
- Only use authentic, authorized components to replace the old ones.

### 3. Accessories

Check that the following accessories are supplied.

Name	Qty	Remark
Manual	1	
Power cord	1	
Key	2	3172(1pcs); 3157(1pcs)
Micro switch	1	
Optical-coupler	1	

### 4. How to Play

Players will attempt to use the “PUNCH” plunger mechanism on the control panel to time the release of the boxing glove mechanism in order to hit the Clown character and stop the moving score. The moving score on the target score board will stop on a ticket score once the boxing mechanism is fully extended. The ticket award stopped on will be dispensed to the Player.

Stopping the moving light on the “JACKPOT” segment located at the top, center of the target score board will award the Jackpot value shown in the LED display.

### 5. Technical Parameter

**Model Number** SN. QD03.01

**Dimension** W 885 × D 1810 × H 1650 (mm) 150 Kgs.

**Power:** Power supply voltage must be according to the label marked on the rear of the machine at the power switch plate.

**Maximum Power** 110V-120V/AC 50-60 Hz

**Fuse Type** 110V, 10A

## 6. Appearance



## 7. All Parts Description and Location

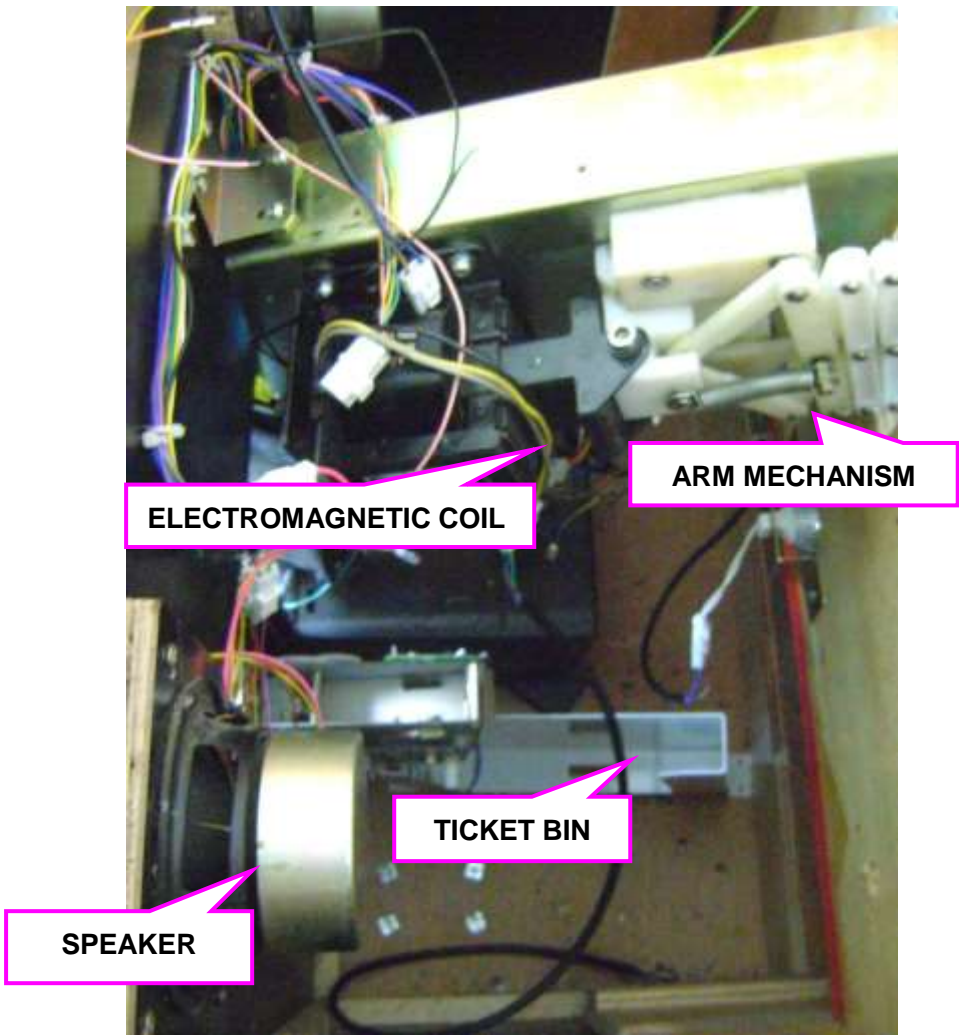
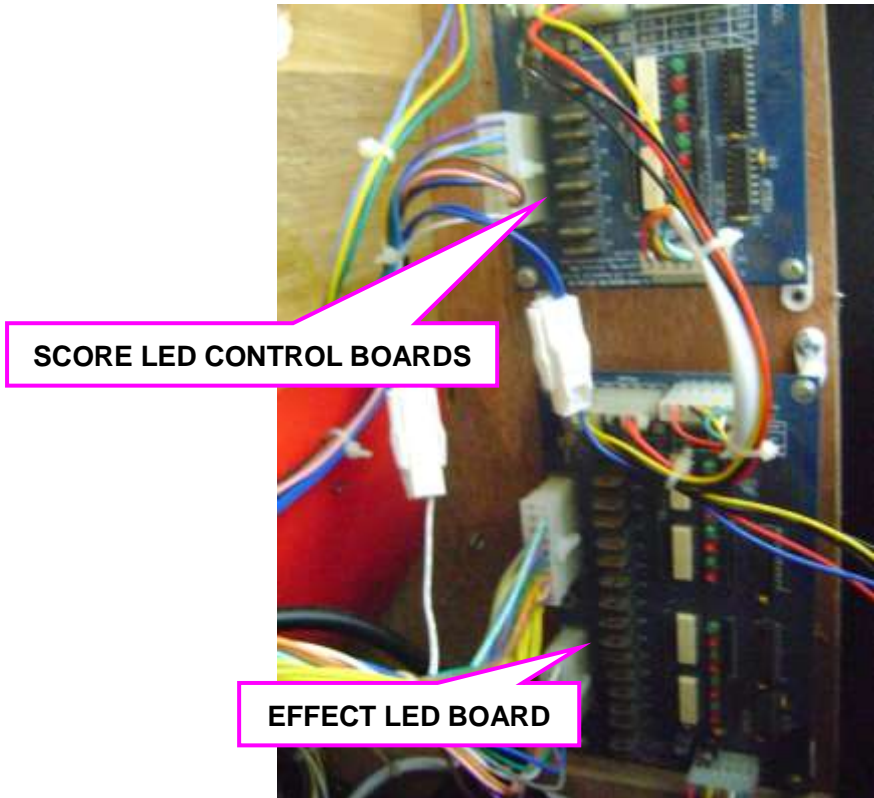

Inside the Back Door Panel:

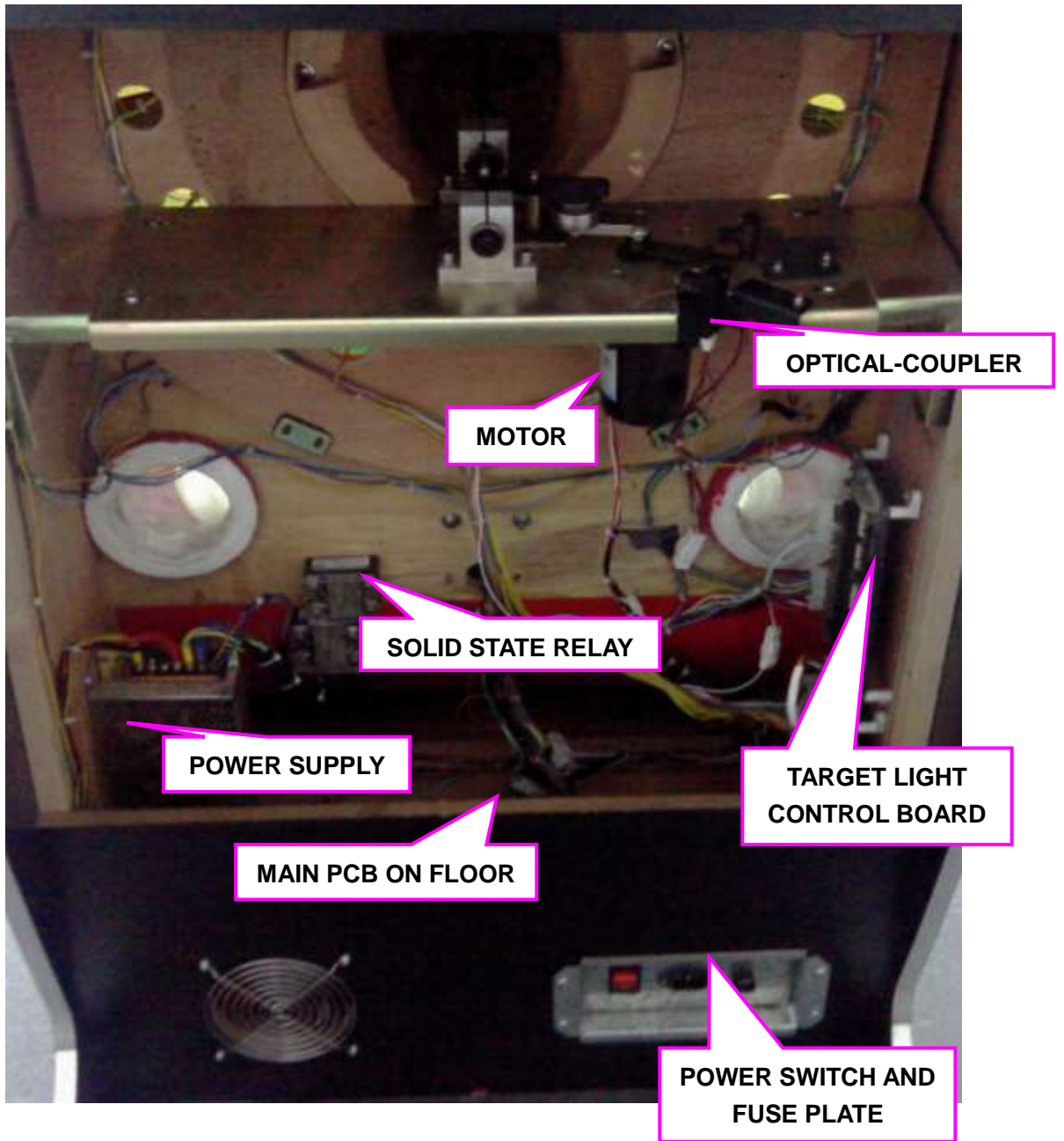

## 8. Component

### 8-1. Meter Board



- **Function Setting Display:** Coin and Ticket Meters and adjustment pushbuttons for accessing the MENU and OPTIONS settings.
- **Total Coins:** Numbers coins inserted to date.
- **Total Tickets:** Numbers of tickets dispensed to date.
- **Clear alarm for no ticket:** When ticket inventory should run empty during a ticket payout and unpaid tickets remain in memory, press this button after installing additional tickets. The unpaid balance remaining in memory will be dispensed to the Player.
- **Jackpot Clear:** clear records and store data.
- **Menu:** Enters the MENU state for making adjustments.
- **Option:** Press this button you can use the menu to adjust the machine.

### 8-2. Power Supply Input Panel

**Power Supply Jack:** One power supply jack, located at the bottom right of the back of the machine.

**Fuse:** There is an AC fuse in the fuse tube. Its specification is  $\phi$  6mm  $\times$  30mm.

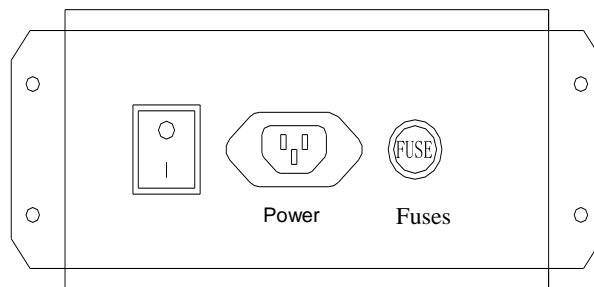

### 8-3. Coin Mechanism.

#### MECHANICAL COIN MECHANISM EXPLANATION

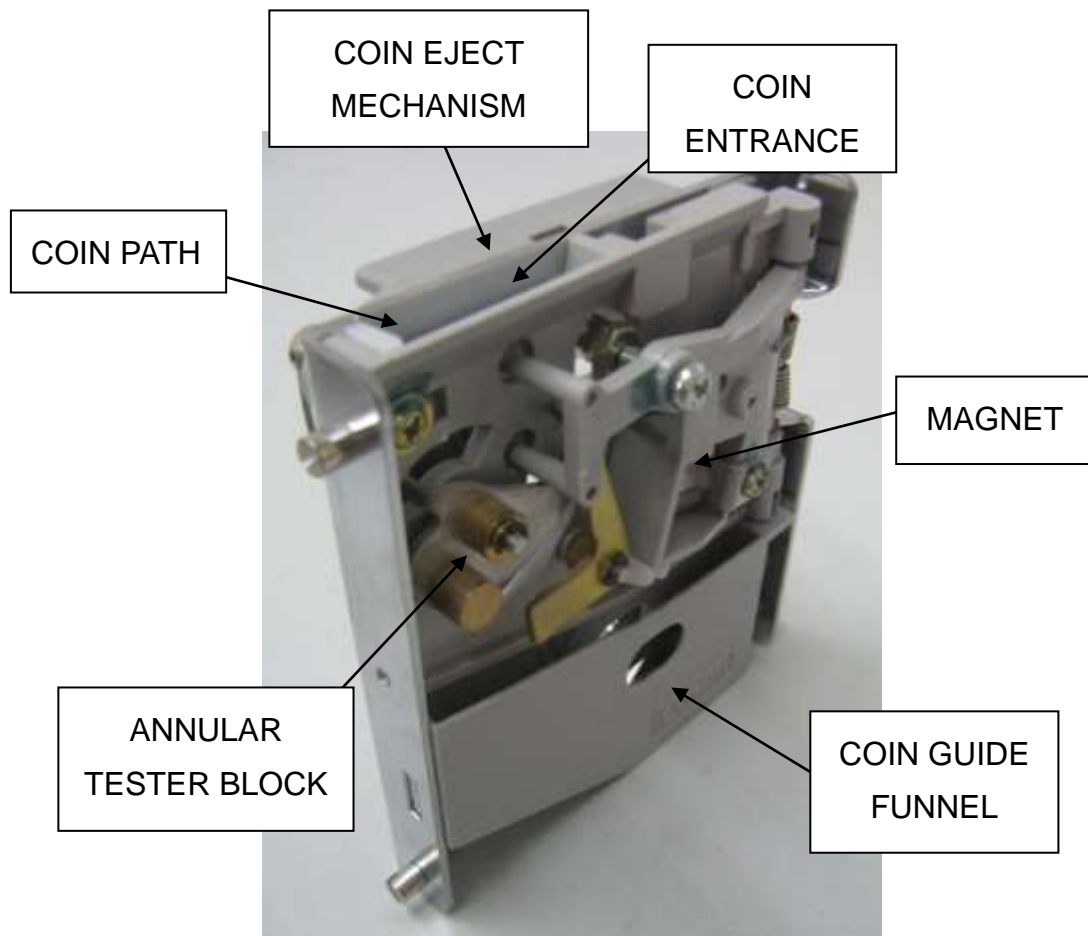

THIS COIN MECHANISM IS A MECHANICAL TYPE. IT HAS THE FUNCTION OF A SUPER MAGNET FOR GUARDING AGAINST COIN CHEAT SUCH AS ANTI-FALSE COIN, ("SLUG") ANTI-FISHING, TAMPERING OR MACHINE INCLINATION.

ACCEPTABLE COIN SIZE:  $\Phi 24\text{MM} \sim \Phi 26\text{MM}$  IN DIAMETER, 1.6MM $\sim$ 2.0MM THICK, EACH COUNTRY HAS VARIOUS SIZE COINS DEPENDING ON THE COIN MECHANISM.

COIN EXIT BUTTON: IF THE INSERTED COIN GETS BLOCKED IN THE COIN SELECTOR, PRESS IT, THE COIN WILL COME OUT OF THE EXIT.

COIN EXIT: IF THE INSERTED COIN IS THE WRONG DENOMINATION, IT WILL USUALLY COME OUT OF THE COIN EXIT AUTOMATICALLY.

COIN PATH MOUTH ADJUSTER BLOCK: ADJUST THE DIAMETER OF THE COIN. IF YOU HAVE TO INSERT ANY SMALLER COIN, MOVE IT RIGHT. IN GENERAL SITUATION, YOU DO NOT INSERT SMALL COINS, SO MOVE THE BLOCK LEFT. IT CAN CONTROL THE DIAMETER OF SUITABLE COINS BY 0.1MM.

ANNULAR TESTER BLOCK: CONTROL FLOOR LEVEL OF DIAMETER OF ACCEPTABLE COIN. USED TOGETHER WITH BLOCKING STICK LIMITATION ADJUSTER PIECE, ADJUSTS THE DIAMETER OF THE COIN TO VARIES WITHIN A LIMITATION OF 0.1MM. COINS OF DIFFERENT SPECIFICATIONS ARE SUITABLE FOR DIFFERENT TYPES OF ANNULAR

TESTER BLOCK. AS FOR TEST BLOCK OF THE SAME SPECIFICATION, THE LARGER IT IS, THE TIGHTER IT IS AND THE SMALLER IS, THE LOOSER IT IS.

MAGNET: SELECT COINS WITH SUITABLE IRON-CONTAINED QUANTITY. THOSE CONTAINING A LARGE IRON QUANTITY EASILY GET ATTRACTED BY THE MAGNET, WHILE THOSE CONTAINING A SMALL IRON QUANTITY GET THROUGH EASILY; IF IRON CONTENT COINS ARE USED, REMOVE THE MAGNET.

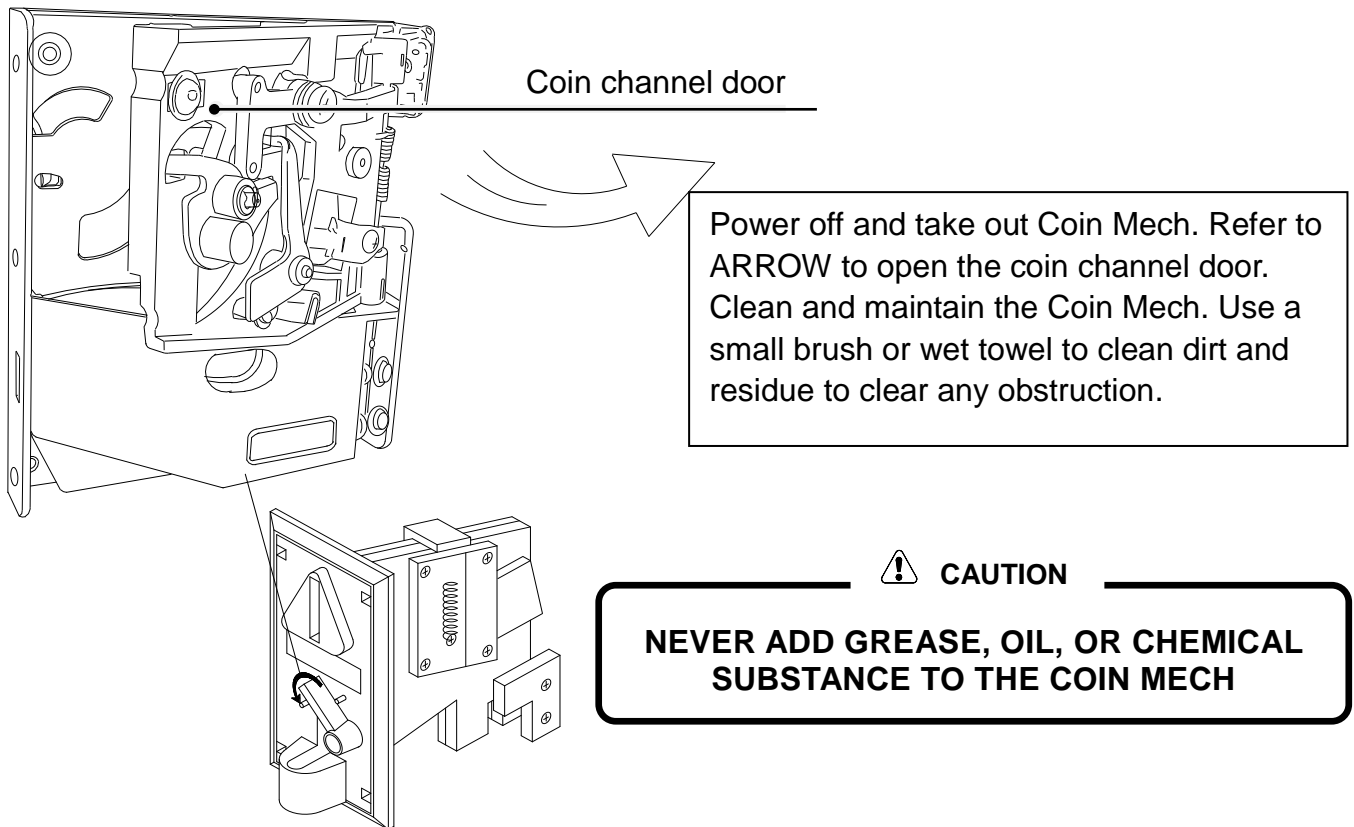

#### 8-4. Ticket Dispenser

##### Installing tickets:

1. As shown on picture1, push the metal block up and lift the aluminum plate;
2. Feed the ticket through the inspecting sensor until they reach the roller and install the ticket.
3. Press the “Reset” button to advance the tickets through the roller.
4. Install the aluminum plate back in place;
5. When all tickets have been dispensed, and an unpaid balance is held in the game memory, press the “jp clear” button on the menu & adjustment panel above the cash box area to dispense remaining balances. This will clear any unpaid tickets from memory.

Continued on the following page:

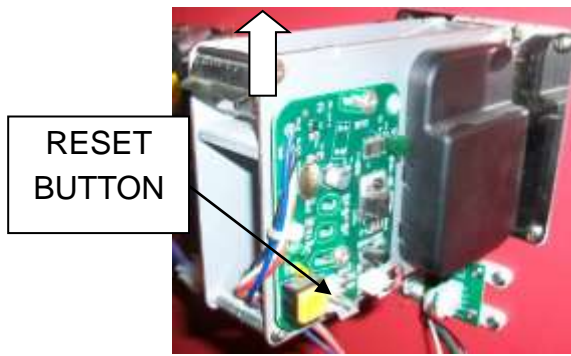

PICTURE 1



PICTURE 2

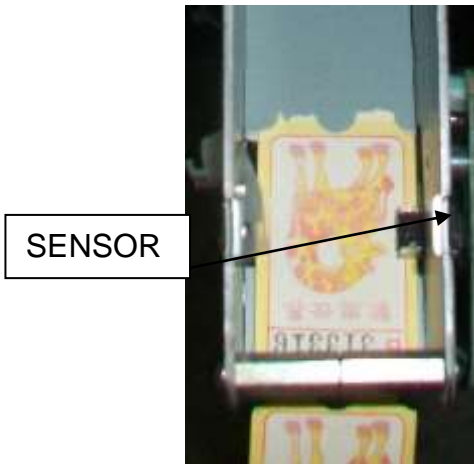

PICTURE 3



PICTURE 4



PICTURE 5

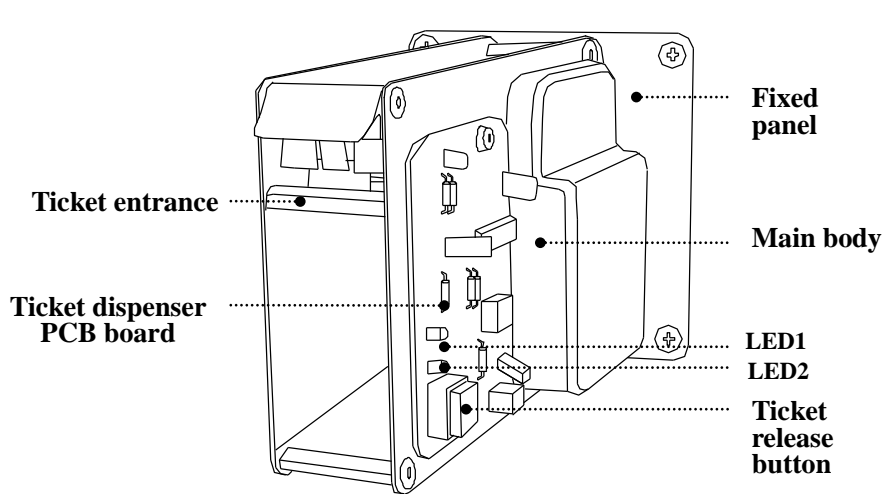
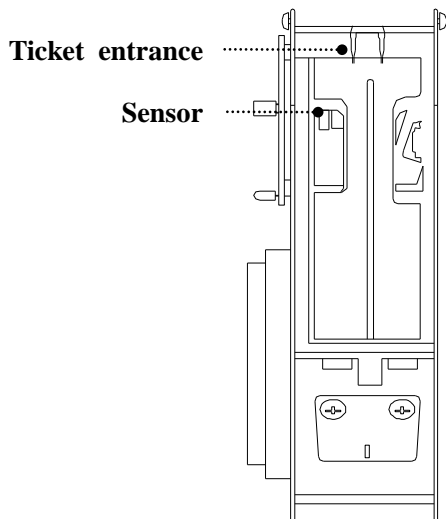

**Ticket entrance:** To load tickets.

**Mounting plate:** To fix the ticket dispenser.

**Tickets exit button:** Press this button and the machine dispenses tickets automatically.

Error Code: E1: Alarm for Coin-In Timeout

E2: Alarm for Ticket-Out Timeout

## 9. PIN Connection on Main Board

Port Code	Port No.	Program Items	I/O No.	Specificati on Of Wiring	Wiring Color	Function
J2	1	+12v		Φ0.3	Yellow	Power supply for Ticket Dispenser
	2	Out1.0	OUT1	Φ0.3	Brown	code table for tokens inserted
	3	+12v		Φ0.3	Yellow	Tokens Selector, power supply for start lamb& code table
	4	Out1.1	OUT2	Φ0.3	Gray	code table for ticket payout
	5	Out1.2	OUT3	Φ0.3		Tokens lamb drivers
	6	Out1.3	OUT4		White	Ticket Dispenser driver
	7	GND		Φ0.3	Black	Ticket Dispenser ground electrode
	8	GND		Φ0.3	Black	Tokens Selector, start button, code table ground electrode
	9	In1.0	IN1	Φ0.3	Light Green	Tokens Selector
	10	In1.1	IN2		Green	payout ticket feedback to ticket dispenser
	11	In1.2	IN3	Φ0.3	Pink	Start signal
	12	In1.3	IN4	Φ0.3		
	13	In1.4	IN5	Φ0.3	Light blue	Menu switch (start or off)
	14	In1.5	IN6	Φ0.3	Blue	Reset switch after big prize
	15	In1.6	IN7	Φ0.3	Orange	stop alarm for ticket shortage
	16	In1.7	IN8	Φ0.3	Purple	sense switch (adjust)
J1	1	+12v		Φ0.3	Yellow	Power supply for speaker & start lamp
	2	+12v		Φ0.3	Yellow	Power supply for alternating electromagnet & flashing lamp on the panel
	3	Out1.4	OUT5		Brown	AC220 alternating electromagnet driver
	4	Out1.5	OUT6		Pink	Start button lamp red 1
	5	Out1.6	OUT7		Orange	Start button lamp red 2
	6	Out1.7	OUT8		Green	Start button lamp red 3
	7	Out2.0	OUT9	Φ0.3	Blue	speaker lamp red

	8	Out2.1	OUT10	Φ0.3	Purple	speaker lamp green
	9	Out2.2	OUT11	Φ0.3	Gray	speaker lamp blue
	10	Out2.3	OUT12	Φ0.3		
	11	Out2.4	OUT13	Φ0.3		
	12	Out2.5	OUT14	Φ0.3		
	13	Out2.6	OUT15	Φ0.3		
	14	Out2.7	OUT16	Φ0.3		
	15	Out3.0	OUT17	Φ0.3		
	16	Out3.1	OUT18	Φ0.3		
	17	Out3.2	OUT19	Φ0.3		
	18	Out3.3	OUT20	Φ0.3		
	19	Out3.4	OUT21	Φ0.3		
	20	Out3.5	OUT22	Φ0.3		
	21	Out3.6	OUT23	Φ0.3		
	22	Out3.7	OUT24			
	1	+5v				
	2	+5v				
<b>J3</b>	3	In2.0	IN9	Φ0.3	Brown	optical coupler catch up the clown head
	4	In2.1	IN10	Φ0.3	Red	Optical coupler for resetting the clown head
	5	In2.2	IN11	Φ0.3	Orange	
	6	In2.3	IN12	Φ0.3	Green	
	7	In2.4	IN13	Φ0.3	Blue	
	8	In2.5	IN14	Φ0.3	Purple	
	9	In2.6	IN15	Φ0.3	Gray	
	10	In2.7	IN16	Φ0.3	White	
	11	In3.0	IN17	Φ0.3	Brown	
	12	In3.1	IN18	Φ0.3	Orange	
	13	In3.2	IN19	Φ0.3	Green	
	14	In3.3	IN20	Φ0.3	Blue	
	15	In3.4	IN21	Φ0.3	Purple	
	16	In3.5	IN22	Φ0.3	Gray	
	17	In3.6	IN23	Φ0.3	White	
	18	In3.7	IN24			
	19	GND		Φ0.3	Black	
	20	GND		Φ0.3	Black	
<b>J5</b>	1	+5v		Φ0.3	Red	Main board--16 post lamp panel 1:left 4,2,8,2,6,2,4,2 score lamps,
	2	GND		Φ0.3	Black	

	3	+12v		Φ0.3	Yellow	right 4,2,8,2,6,2,4,2score lamps. 16 post lamp panel 2:JP1-1 big prize lamp, 2 motor drive for the clown action, 4 reflector lamp drive 5 box spotlight control, 6 front-panel flashing light 1,2,3.JP2-1 nixie tube for big prize1, 2,3,
	4	CTL		Φ0.3	Brown	
	5	DI		Φ0.3	Green	
	6	CLK		Φ0.3	White	
J6	1	+5v		Φ0.3	Red	Main board – Jackpot display for big prize(4post)-adjust Jackpot (4post)
	2	GND		Φ0.3	Black	
	3	+12v		Φ0.3	Yellow	
	4	CTL		Φ0.3	Brown	
	5	DI		Φ0.3	Green	
	6	CLK		Φ0.3	White	
J7	1	+5v		Φ0.5	Red	Power input
	2	GND		Φ0.5	Black	
	3	GND			Black	
	4	+12v		Φ0.5	Yellow	
J8	1	GND		Φ0.5	Purple	Speaker (left)
	2	L		Φ0.5	Green	Speaker (right)
	3	GND		Φ0.5	Purple	
	4	R		Φ0.5	Blue	

## 10. Function: MENU & OPTION Adjustment Tables

In standby mode, (non-game play), press the MENU Button to enter into the MENU Function Settings & Score Settings.

**The MENU Function Settings:** the first two digits of the JACKPOT LED display the current MENU. The third and fourth LED display position display the desired OPTION;

**The Score Settings :** the first 2 digits of the LED display Menu, 2<sup>nd</sup> 2 digits display desired OPTION within that MENU. Adjust the setting button to set the OPTION as follows. Continue to press MENU back to -0-0- to exit and save the settings.

### MENU and OPTIONs Directory

MENU #      OPTION#

[JACKPOT DISPLAY]

00

00

**MENU and OPTIONs Directory**

MENU #    OPTION#

**00      00****\*NOTES FACTORY DEFAULT SETTING****DISPLAYED ON THE JACKPOT  
SCORE AND TICKET DISPLAY**

<b>MENU#</b>	<b>OPTION#</b>	<b>ACTION</b>
00	00	Return to Game Play
1	00	Free Play
1	01	1 Credit Play
1	02 *	2 Credit Play *
1	03	3 Credit Play
1	04	4 Credit Play
2	00	Tickets OFF – no tickets dispensed.
2	01*	Tickets ON [1 pt. ticket value]
2	02	Tickets ON [2 pt. ticket value]
3	01	Jackpot Level Win Ratio: 1 in 1 [every time]
3	02 *	Jackpot Level Win Ratio: 1 in 2
3	03	Jackpot Level Win Ratio: 1 in 3
3	04	Jackpot Level Win Ratio: 1 in 4
3	05	Jackpot Level Win Ratio: 1 in 5
3	06	Jackpot Level Win Ratio: 1 in 6
3	07	Jackpot Level Win Ratio: 1 in 7
3	08	Jackpot Level Win Ratio: 1 in 8
3	09	Jackpot Level Win Ratio: 1 in 9
3	10	Jackpot Level Win Ratio: 1 in 10
3	11	Jackpot Level Win Ratio: 1 in 11
3	12	Jackpot Level Win Ratio: 1 in 12
3	13	Jackpot Level Win Ratio: 1 in 13
3	14	Jackpot Level Win Ratio: 1 in 14
3	15	Jackpot Level Win Ratio: 1 in 15
3	16	Jackpot Level Win Ratio: 1 in 16
3	17	Jackpot Level Win Ratio: 1 in 17
3	18	Jackpot Level Win Ratio: 1 in 18
3	19	Jackpot Level Win Ratio: 1 in 19
3	20	Jackpot Level Win Ratio: 1 in 20
3	21	Jackpot Level Win Ratio: 1 in 25
3	22	Jackpot Level Win Ratio: 1 in 30
3	23	Jackpot Level Win Ratio: 1 in 35

3	24	Jackpot Level Win Ratio: 1 in 40
3	25	Jackpot Level Win Ratio: 1 in 45
3	26	Jackpot Level Win Ratio: 1 in 50
3	28	Jackpot Level Win Ratio: 1 in 60
3	29	Jackpot Level Win Ratio: 1 in 70
3	30	Jackpot Level Win Ratio: 1 in 80
3	31	Jackpot Level Win Ratio: 1 in 90
3	32	Jackpot Level Win Ratio: 1 in 100

\*The following setting is ONLY for the use of the OPTIONAL Jackpot “Big Bop Bonanza” display accessory which is mounted on top of 3 or more game units. This setting independently sets the frequency of how often 3 Jackpot awards are won in a row which is the win criteria for the accessory Jackpot win on a single game. When the accessory Jackpot is won, according to the win ratios below, the winning game will send a signal to the accessory Jackpot device to activate it.

4	01	Option Jackpot Win Ratio: OFF [no Jackpot enabled]
4	02	Option Jackpot Win Ratio: 1 in 5
4	03	Option Jackpot Win Ratio: 1 in 5
4	04	Option Jackpot Win Ratio: 1 in 10
4	05	Option Jackpot Win Ratio: 1 in 15
4	06	Option Jackpot Win Ratio: 1 in 20
4	07	Option Jackpot Win Ratio: 1 in 25
4	08	Option Jackpot Win Ratio: 1 in 30
4	09	Option Jackpot Win Ratio: 1 in 35
4	10*	Option Jackpot Win Ratio: 1 in 40
4	11	Option Jackpot Win Ratio: 1 in 45
4	12	Option Jackpot Win Ratio: 1 in 50
4	13	Option Jackpot Win Ratio: 1 in 60
4	14	Option Jackpot Win Ratio: 1 in 70
4	15	Option Jackpot Win Ratio: 1 in 80
4	16	Option Jackpot Win Ratio: 1 in 90
4	17	Option Jackpot Win Ratio: 1 in 100
4	18	Option Jackpot Win Ratio: 1 in 120
4	19	Option Jackpot Win Ratio: 1 in 130
4	20	Option Jackpot Win Ratio: 1 in 140
4	21	Option Jackpot Win Ratio: 1 in 150
4	22	Option Jackpot Win Ratio: 1 in 160
4	23	Option Jackpot Win Ratio: 1 in 170
4	24	Option Jackpot Win Ratio: 1 in 180
4	25	Option Jackpot Win Ratio: 1 in 190
4	26	Option Jackpot Win Ratio: 1 in 200
4	27	Option Jackpot Win Ratio: 1 in 210
4	28	Option Jackpot Win Ratio: 1 in 230
4	29	Option Jackpot Win Ratio: 1 in 240

4	30	Option Jackpot Win Ratio: 1 in 250
4	31	Option Jackpot Win Ratio: 1 in 260
4	32	Option Jackpot Win Ratio: 1 in 270
4	33	Option Jackpot Win Ratio: 1 in 280
4	34	Option Jackpot Win Ratio: 1 in 290
4	35	Option Jackpot Win Ratio: 1 in 300
4	36	Option Jackpot Win Ratio: 1 in 325
4	37	Option Jackpot Win Ratio: 1 in 350
4	38	Option Jackpot Win Ratio: 1 in 375
4	39	Option Jackpot Win Ratio: 1 in 400
4	40	Option Jackpot Win Ratio: 1 in 425
4	41	Option Jackpot Win Ratio: 1 in 450
4	42	Option Jackpot Win Ratio: 1 in 475
4	43	Option Jackpot Win Ratio: 1 in 500
4	44	Option Jackpot Win Ratio: 1 in 550
4	45	Option Jackpot Win Ratio: 1 in 600
4	46	Option Jackpot Win Ratio: 1 in 650
4	47	Option Jackpot Win Ratio: 1 in 700
4	48	Option Jackpot Win Ratio: 1 in 800
4	49	Option Jackpot Win Ratio: 1 in 900
4	50	Option Jackpot Win Ratio: 1 in 1000
5	00	No Mercy ticket
5	01	1 mercy ticket
5	02*	2 mercy tickets
5	03	3 mercy tickets
5	04	4 mercy tickets
5	05	5 mercy tickets
6	00	Attract OFF
6	01	Attract every 15 seconds
6	02	Attract every 30 seconds
6	03*	Attract every 45 seconds *
6	04	Attract every 60 seconds
6	05	Attract every 90 seconds
6	06	Attract every 120 seconds
6	07	Attract every 180 seconds
7	01	Jackpot Value: 25
7	02	Jackpot Value: 50
7	03	Jackpot Value: 75
7	04	Jackpot Value: 100
7	05	Jackpot Value: 125
7	06	Jackpot Value: 150
7	07	Jackpot Value: 175

7	08*	Jackpot Value: 200
7	09	Jackpot Value: 225
7	10	Jackpot Value: 250
7	11	Jackpot Value: 275
7	12	Jackpot Value: 300
7	13	Jackpot Value: 350
7	14	Jackpot Value: 400
7	15	Jackpot Value: 450
7	16	Jackpot Value: 500
7	17	Jackpot Value: 550
7	18	Jackpot Value: 600
7	19	Jackpot Value: 650
7	20	Jackpot Value: 700
7	21	Jackpot Value: 750
7	22	Jackpot Value: 800
7	23	Jackpot Value: 850
7	24	Jackpot Value: 900
7	25	Jackpot Value: 950
7	26	Jackpot Value: 1000
7	27	Jackpot Value: 1500
7	28	Jackpot Value: 2000
7	29	Jackpot Value: 2500
7	30	Jackpot Value: 3000

TEST FUNCTIONS:

8	00	Test: All controlled lamps flash
8	01	Test: Press "BOP" extends mechanism
8	02	Test: Control panel "BOP" pushbutton – "ding"
8	03	Test: Press "BOP" face linkage withdraws/resets
8	04	Test: Coin mechanisms – coin entered:"ding"
8	05	Test: Ticket mech: Press "BOP" dispense one ticket
8	06	Test: Flash Jackpot display- all 4 blocks
8	07	Test: Audio



THIS GAME IS THE ORIGINAL INTELLECTUAL PROPERTY OF STING INTERNATIONAL  
 © COPYRIGHT 2013 ALL RIGHTS RESERVED